

LINCOOL

GREEN  
ENERGY



LINCOOL | 佛山天之意空调设备有限公司  
Foshan Tianzhiyi Air-conditioning Equipment Co.,Ltd

Add: No.14 Building, Shannan Industrial Estate, Songgang, Shishan  
Town, Nanhai District, Foshan, Guangdong.

Email: heatsales@126.com

Tel/wechat: 86-15986067672 / 15917018802

website: www.ecolincool.com

## 佛山天之意空调设备有限公司

Foshan Tianzhiyi Air-conditioning Equipment Co.,Ltd

Main products include air source heat pumps, ground source heat pumps,  
inverter heat pumps, EVI heat pumps, high temp heat pumps, split heat pumps,  
swimming pool heat pumps.



## About us

Foshan Tianzhiyi Air-conditioning Equipment Co., Ltd located at Foshan city, Guangdong, China, is the leading heat pump and refrigeration unit designer, manufacturer and exporter dedicated in supplying finest quality heating solutions to worldwide customers. We have over 20 professional hvac experts and 8,000 square meters factory. Our innovative, high quality products and solutions include classic air water heat pump, Geothermal heat pump, inverter heat pump, -25° C low temp working heat pump, 80° C high temp heat pump, commercial hvac, etc.

Product innovation, quality assurance and customer satisfaction are our long term commitment to our partners. We have been kept on investing in technological innovation and product optimization with our more than 20 talented experts. Cooperated with domestic famous universities like Hunan University in heating temperature control system, structure design and refrigeration system optimization, and we had got more than 10 patents, become the leading hvac solution brand in China.

## Contents

01	Enterprise honor.....	01
02	Branded components.....	02
03-06	Water system installation chart.....	03
07-08	Air Heat Pump Heating and Hot water (TAN series).....	07
09	High Temp Heat Pump (TAH series).....	09
10	Inverter Air Heat Pump (TAN-BP series).....	10
11-12	Swimming Pool Heat Pump (TAS series).....	11
13-14	EVI Air Heat Pump Heating and Hot Water (TAE series).....	13
15	Split Air to Water Heat Pump (TAN-S series).....	15
16	Household heat pump (TAN-FT/ZT series).....	16
17-18	Air Heat Pump Cooling and Heating (TAN-R series).....	17
19-20	EVI Air Heat Pump Cooling / Heating (TAE-R series).....	19
21-22	Ground Heat Pump Heating and Hot Water (TWN series).....	21
23-24	Ground Heat Pump Cooling / Heating (TWN-R series).....	23
25	Air Heat Cooling/Heating Hot Water Unit(TAM series).....	25
26	Ground Heat Cooling/Heating Hot Water (TWM series).....	26
27	Air-conditioning Fan Unit.....	27
28	Water tank.....	28



Branded components



Copper tube heat exchanger



Plate Heat Exchanger



Electronic Expansion Valve



Heat Exchanger (Titanium pipe)



Compressor



Wilo water Pump



Electrical Heater



water flow switch

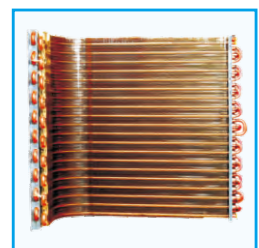

Air heat exchanger



Refrigerant



Connection pipe



Wire controller

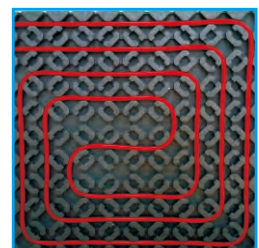

under-floor heating module



Tube to tube heat exchanger

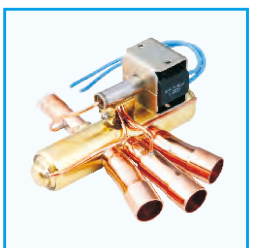

4 way valve



Fan motor

## Air source heat pump installation chart

### HOT WATER

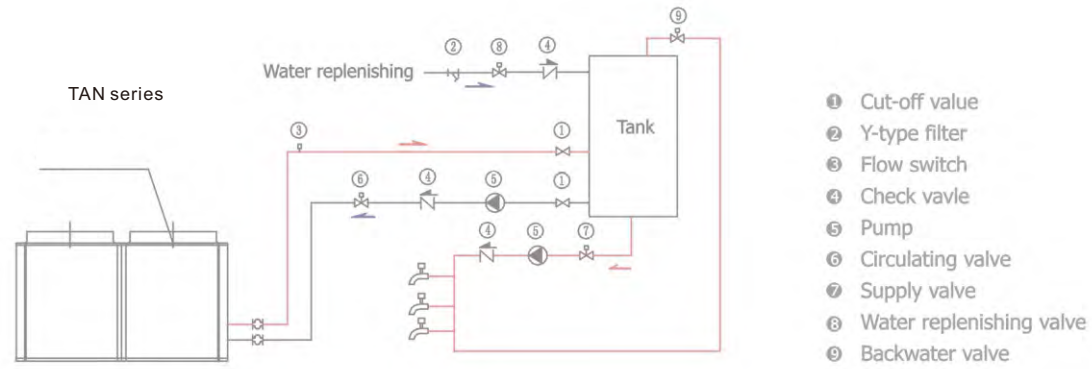

### HOT WATER+HEATING

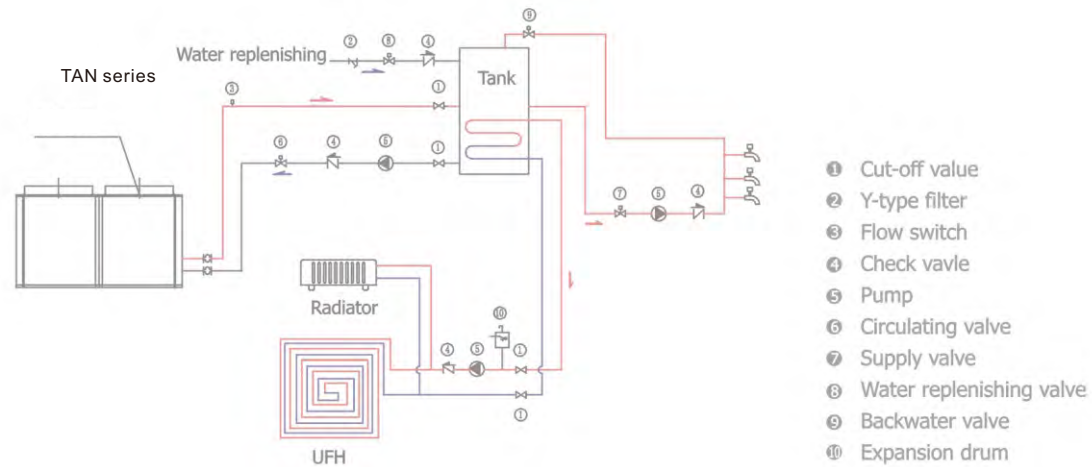

### HOT WATER+HEATING+HEATING SWIMMING POOL

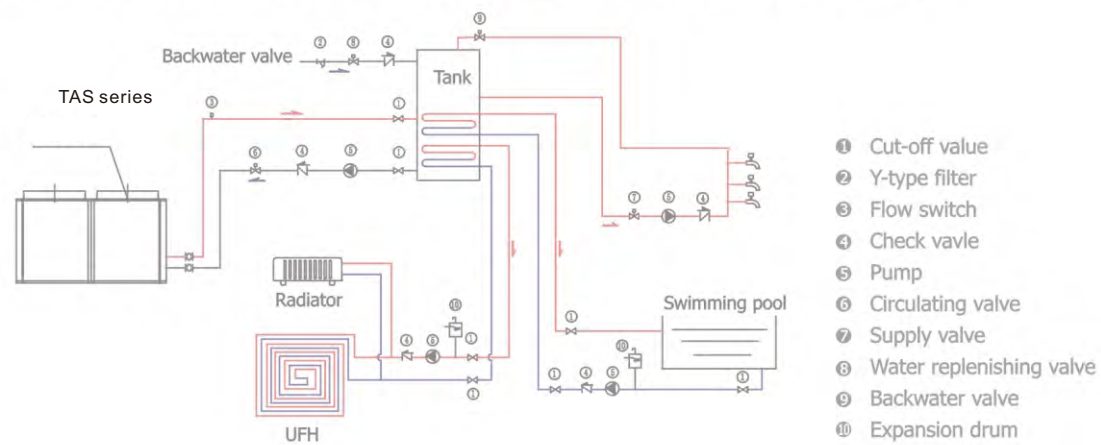

### HOT WATER+COOLING+HEATING

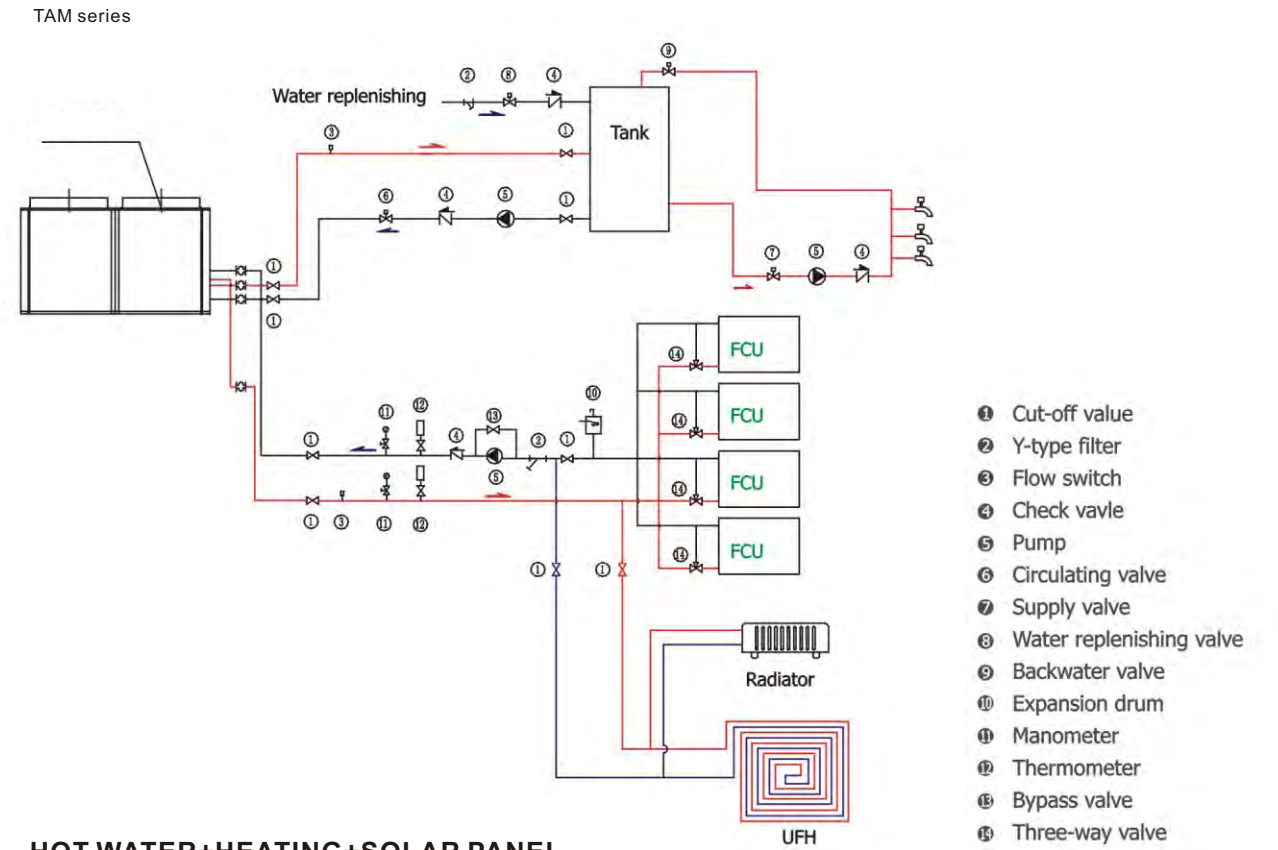

### HOT WATER+HEATING+SOLAR PANEL

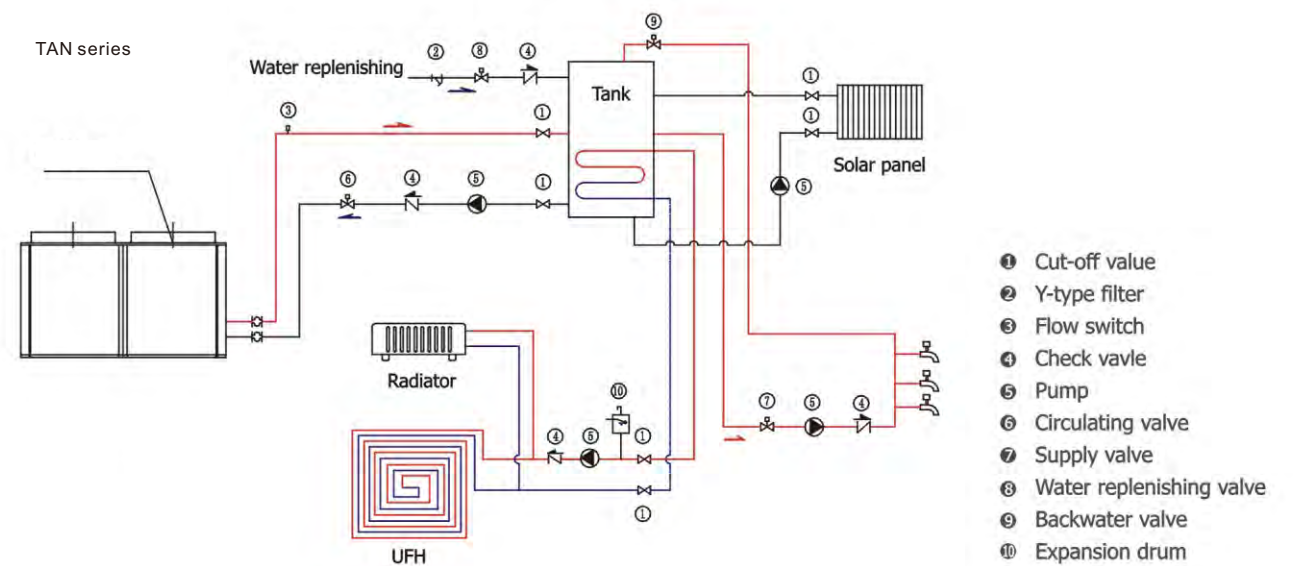

## Water source heat pump installation chart

### HOT WATER

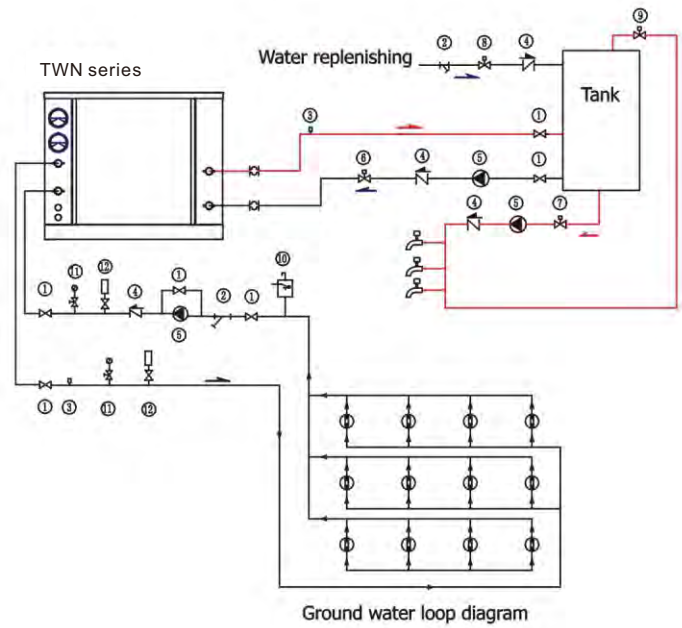

- ❶ Cut-off value
- ❷ Y-type filter
- ❸ Flow switch
- ❹ Check valve
- ❺ Pump
- ❻ Circulating valve
- ❼ Supply valve
- ❽ Water replenishing valve
- ❾ Backwater valve
- ❿ Expansion drum
- ⓫ Manometer
- ⓬ Thermometer
- ⓭ Bypass valve

### HOT WATER+HEATING

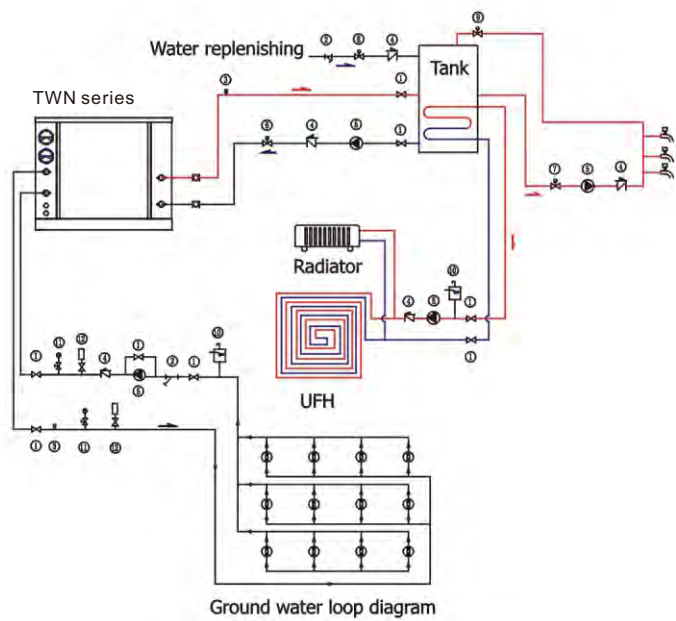

- ❶ Cut-off value
- ❷ Y-type filter
- ❸ Flow switch
- ❹ Check valve
- ❺ Pump
- ❻ Circulating valve
- ❼ Supply valve
- ❽ Water replenishing valve
- ❾ Backwater valve
- ❿ Expansion drum
- ⓫ Manometer
- ⓬ Thermometer
- ⓭ Bypass valve

### HOT WATER+COOLING+HEATING

TWM series

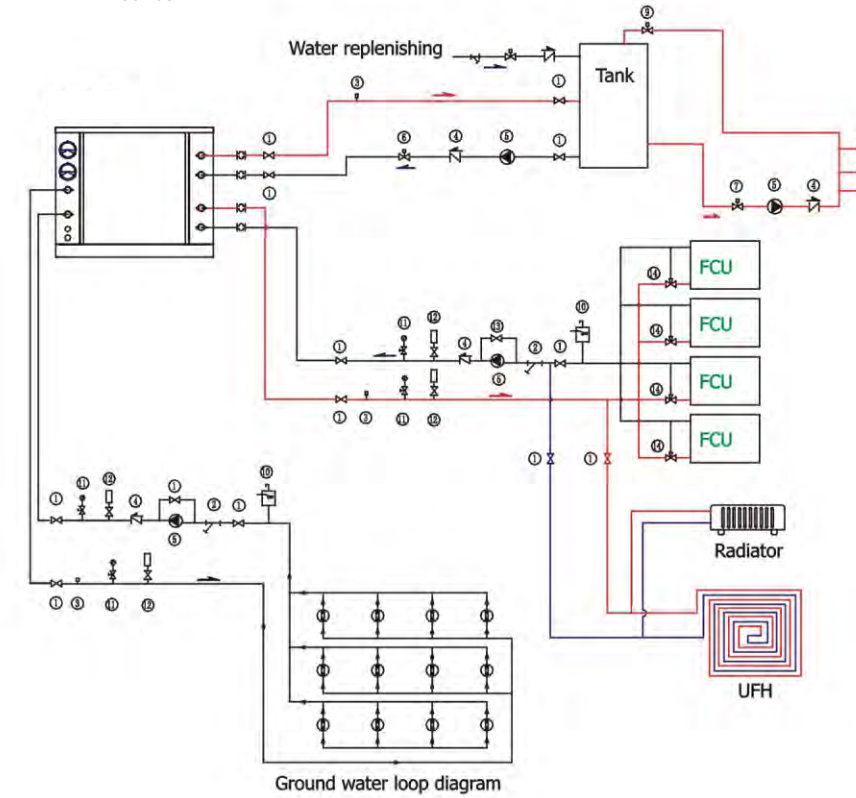

- ❶ Cut-off value
- ❷ Y-type filter
- ❸ Flow switch
- ❹ Check valve
- ❺ Pump
- ❻ Circulating valve
- ❼ Supply valve
- ❽ Water replenishing valve
- ❾ Backwater valve
- ❿ Expansion drum
- ⓫ Manometer
- ⓬ Thermometer
- ⓭ Bypass valve
- ⓮ Three-way valve

### GEOTHERMAL EXCHANGER SCHEMATIC DRAWING

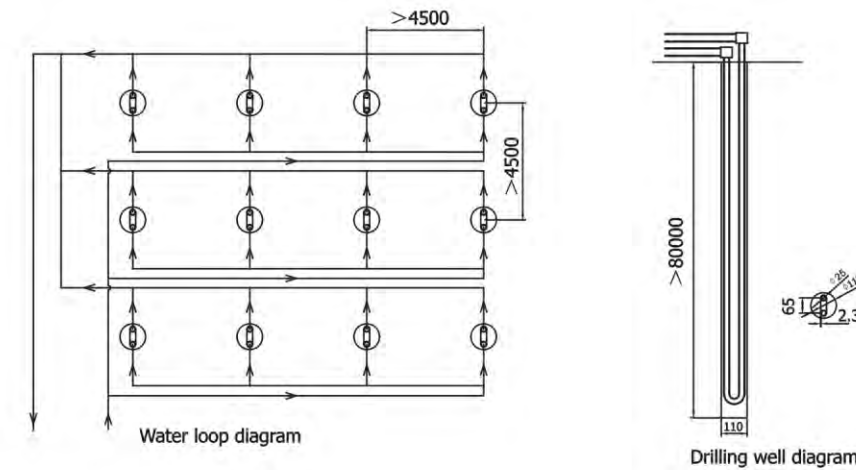

#### Underground heat exchanger design requirements

1. The flow of each well 2 to 3 gallons/min, flo rate of 0.8-1.2m/s
2. Heat exchange tube  $\varnothing 25 \times 2.3\text{mm}$  using the PE pipe, heat transfer coefficient: 23-38W/m pipe(46-76W/m well). 0.8-1.2m/s
3. The same distance from the water loop design, to ensure that uniform distribution of water flow loop

### Product Features



- High-efficient scroll compressor Copeland /Sanyo /Daikin optional.
- R410A/R417A/R407C HCHF refrigerant, good to environment.
- Base frame external panels made of polyester powder coated steel or stainless steel.
- Reverse cycle valve.
- Careful protection functions as high pressure, low pressure, overheating, overload, anti-freezing, defrosting, phase order, discharge temp, etc.
- Intelligent controller adjustment by quick-mind microprocessor.
- General testing and operational test carried out for every unit before package in the factory.

### Technical Parameters

Model		TAN-02	TAN-03	TAN-035	TAN-04	TAN-05	TAN-06	TAN-07	
Rated heating capacity	kW	7.2	11.8	13.9	15.5	19.0	23.5	27.5	
Rated power input	kW	1.7	2.45	2.9	3.4	4.1	5.1	5.9	
Hot water output	T/H	0.15	0.23	0.29	0.32	0.39	0.48	0.57	
Input current	A	7.2	11.5/4.1	14.5/5.8	16.5/6.7	6.7	8	11	
Max running current	A	11	17.1/7.5	21.5/9.5	25.5/12	12	14	16	
COP	kW/kW	4.2	4.8	4.8	4.5	4.6	4.6	4.67	
Rated/Max outgoing water temp	°C	55°C/60°C							
Power supply	V/Ph/Hz	220V~/50Hz	220V/1Ph or 380V/3Ph			380V/3Ph/50Hz			
Noise level	dB(A)	53	55	55	62	62	62	63	
Unit dimension	Length(A)	mm	1000	*1030/710	*1030/710	*770/750	*1030/750	*1030/750	*1340/920
	Width(B)	mm	300	*480/710	*480/710	*420/750	*480/750	*480/750	*490/860
	Height(C)	mm	620	*800/840	*800/840	*1250/1030	*1340/1030	*1340/1030	*1410/1170
Unit Weight	kg	75	115	125	140	145	155	175	
Operating temp limits: Air	°C	-15°C - 43°C							
Throttle		EEV							
Refrigerant charge qty	kg	1.25	1.7	1.8	2	2.5	2.5	2.7	
Compressor		Rotary Panasonic	Scroll Copeland, Sanyo, Daikin optional						
Compressor qty	pcs	1	1	1	1	1	1	1	
Evaporator		Blue finned aluminum tube heat exchanger							
Hot water side	Heat exchanger type		High efficiency tank type heat exchanger						
	Water flow	m³/h	1.60	2.30	2.60	3.10	3.50	4.20	4.80
	Connection in / out	DN	20	20	20	25	25	25	32

Test conditions: air source side DB/WB is 20°C / 15°C, inlet water temp 15°C, outlet water temp 55°C.

### Product Features



- Save Electricity 75%  
Use One Unit Electricity, Can Produce 4 Units Hot Water, save Energy And High Efficiency.
- Modular design  
With modular design, compressor automatically starts and stops with sequence, running more stable.
- Easy operation,  
Intelligent control panel, easily control the temperature needed, can set timer ON/OFF.
- High efficiency  
Heat pump its consumption only 1/4 of electric heater, 1/3 of gas heater, 1/2 of solar energy.

### Technical Parameters

Model		TAN-10	TAN-12	TAN-15	TAN-20	TAN-25	TAN-30	TAN-50	
Rated heating capacity	kW	38.0	47.0	58.0	76.0	92.0	103.0	182.0	
Rated power input	kW	8.2	10.2	12.7	16.7	20.5	23.2	41	
Hot water output	T/H	0.77	0.97	1.21	1.55	1.93	2.2	3.87	
Input current	A	13.34	16	20	26.51	33.1	40	66	
Max running current	A	24	28	36	48	56	72	112	
COP	kW/kW	4.6	4.6	4.6	4.55	4.5	4.44	4.44	
Rated/Max outgoing water temp	°C	55°C/60°C							
Power supply	V/Ph/Hz	380V/3Ph/50Hz							
Noise level	dB(A)	63	64	66	68	68	68	72	
Unit dimension	Length(A)	mm	*1500/1450	1500	1500	1850	2000	2000	2300
	Width(B)	mm	*440/780	700	800	1000	1100	1100	1260
	Height(C)	mm	*1705/1050	1350	1500	1950	1930	2070	2250
Unit Weight	kg	245	280	310	560	630	850	1350	
Operating temp limits: Air	°C	-15°C - 43°C							
Throttle		EEV							
Refrigerant type		R410A/R417A/R407C optional							
Refrigerant charge qty	kg	2.5*2	2.7*2	3.5*2	3.5*2	5.5*2	6.5*2	3.2*4	
Compressor		Scroll Copeland, Sanyo, Daikin optional							
Compressor qty	pcs	2	2	2	2	2	2	4	
Evaporator		Blue finned aluminum tube heat exchanger							
Hot water side	Heat exchanger type		Tank type		Shell tube heat exchanger				
	Water flow	m³/h	6.50	7.80	9.80	13.00	16.50	20.50	32.00
	Connection in / out	DN	32	32	40	50	50	65	80

Test conditions: air source side DB/WB is 20°C / 15°C, inlet water temp 15°C, outlet water temp 55°C.

# High Temp Heat Pump

## Heating and Hot Water (TAH series)

### Product Features



- High-efficient scroll compressor Copeland.
- High temp 70/ 80degree hot water output.
- R134A/R417A refrigerant.
- Base frame external panels made of polyester powder coated steel or stainless steel.
- Reverse cycle valve.
- Compact structure and sound control design to compressor and fan.
- Added area air exchanger sure of good performance
- Automatic defrosting and anti-freezing function
- Careful protection functions as high pressure. low pressure, overheating, overload, anti-freezing, phase order, discharge temp, etc.
- Intelligent controller adjustment by quick-mind microprocessor.
- Timer On/Off at customer setting
- General testing and operational test carried out for every unit before package in the factory

### Technical Parameters

Model		TAH-03	TAH-05	TAH-06	TAH-10	TAH-12	TAH-20	
Heating capacity	kW	8	13.2	16.1	26.6	32	55	
Input power	kW	2.55	4.2	5.1	8.5	10.3	17.5	
Input current	A	4.2	7.6	8.9	15.2	17.8	30.4	
Max running current	A	7.5	12	13	24	26	48	
Power source	V/Ph/Hz	380V/3Ph/50Hz						
Nosie level	dB(A)	53	60	60	63	64	68	
Unit size	Length(A)	620	680	680	800	800	1700	
	Width(B)	725	800	800	1080	1080	900	
	Height(C)	595	720	720	1050	1050	1250	
Unit quality	kg	120	155	170	245	280	450	
Working temp range	°C	-15°C—43°C						
Refrigerant		R134A/R417A						
Refrigerant charge qty	kg	1.7	2.3	2.8	2.3*2	2.8*2	4.5*2	
Compressor		Scroll Compressor Copeland						
Compressor qty	pcs	1	1	1	2	2	2	
Evaporator		Blue finned aluminum tube heat exchanger						
Hot water side	Heat exchanger type	Tank type/copper tube in tube heat exchanger optional						
	Water flow	m <sup>3</sup> /h	2.3	4.0	4.5	7.0	8.0	15
	Connection in / out	DN	20	25	25	32	32	50

Test heating condition: Ambient temp 20°C /15°C, inlet water temp 20°C, outlet water temp 75°C.

# Inverter Air Source Heat Pump

## (TAN-BP series)

# LINCOOL

### Product Features

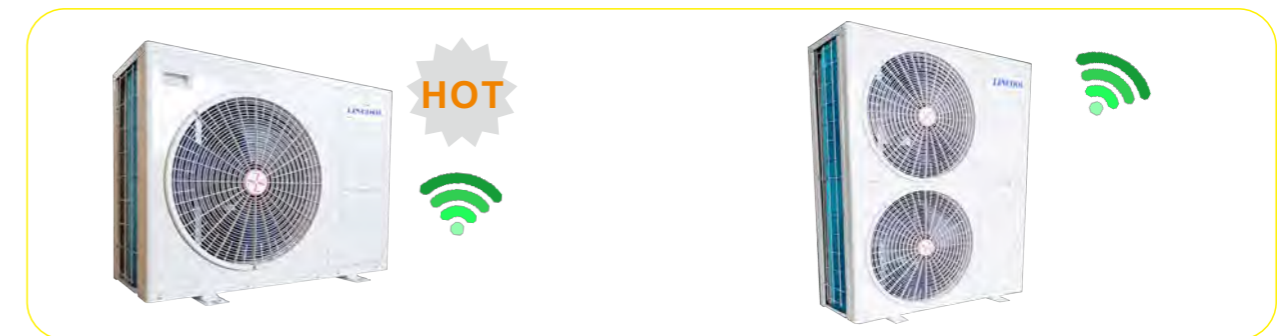

- Compact structure and sound control design.
- Branded components are adopted.
- Scroll compressor, with R410A system design, maximum 60DegC hot water.
- Auxiliary electric heating control possibility.
- Low ambient working temp -30°C design.
- Automatic anti-freeze function and defrosting function.
- Equipped with quick-mind wired LCD controller, timer ON/OFF function.

### Technical Parameters

Model		TAN-03BP	TAN-05BP	TAN-06BP	TAN-08BP	TAN-10BP	
Heating	Heating capacity	KW	8.6	15.5	18.3	23.1	33.2
		BTU	29343	52886	62440	78817	113278
	Input power	KW	2.45	4.35	5.1	6.7	9.5
Cooling	Cooling capacity	KW	7.6	13.5	15.9	19.5	26.2
		BTU	25931	46062	54251	66534	89394
	Input power	KW	2.5	4.4	5.2	6.5	8.75
	Cooling running current	A	12.6	12.2	14.5	20.5	26
	Heating running current	A	13.7	12.8	15	20.8	27
	Max running current	A	17	16	18	24	32
	Power source	V/Ph/Hz	220V/1N/50HZ	380V/3N/50HZ			
	Noise level	dB(A)	<55	<58	<59	<64	<64
Outdoor size	Side fan W x D x H	mm	1030*480*820	1030*480*1340	1030*480*1340	1350*480*1350	1350*480*1350
	Unit weight	kg	115	155	165	190	210
	Working temp range	°C	-15°C-43°C				
	Throttle type		Electric expansion valve				
Refrigerant	Type		R410A/R32				
Compressor	Inverter Rotary Compressor		Mitsubishi/GMCC optional				
Air source side	Heat exchanger type		Finned tube heat exchanger				
	Motor power	KW	0.06	0.06*2	0.06*2	0.12*2	0.12*2
Hot water side	Heat exchanger type		Copper tube in tube heat exchanger				
	Water flow	m <sup>3</sup> /H	2.3	3.2	3.6	4.2	4.8
	Water pressure loss	kPa	20	25	25	30	32
	Pipe size	DN	20	25	25	25	32

Test conditions:

- 1.Cooling: Air source side DB/WB is 35°C/--, inlet water temp 12°C, outlet water temp 7°C.
- 2.Heating: Air source side DB/WB is 7°C/6°C, inlet water temp 40°C outlet water temp 45°C.

## Product Features

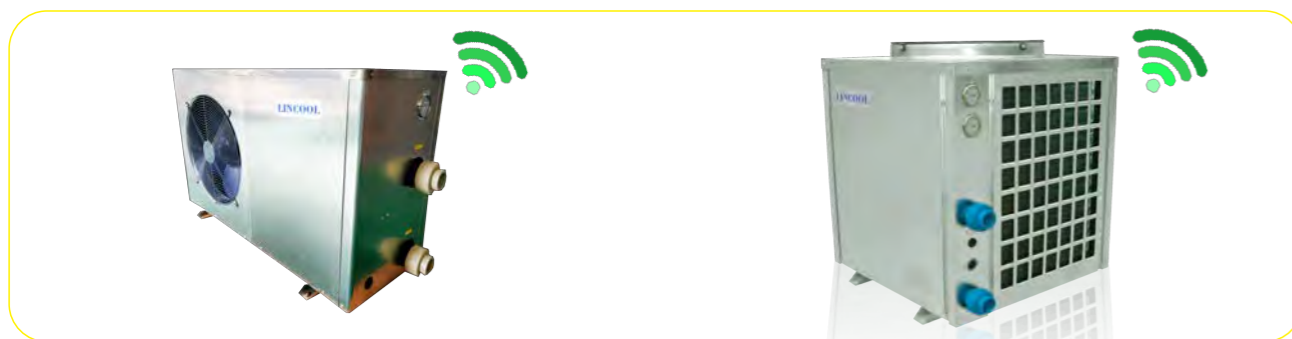

- » High-efficient scroll compressor Copeland / Sanyo / Daikin optional
- » R410A/R417A/R407C HCHF refrigerant optional, good to environment.
- » Base frame external panels made of polyester powder coated steel or stainless steel.
- » Titanium heat exchanger built-in with good anti-corrosion effect.
- » Intelligent controller adjustment by quick-mind microprocessor.
- » General testing and operational test carried out for every unit before package in the factory

## Technical Parameters

Model		TAS-02	TAS-03	TAS-05	TAS-06	TAS-07
Rated heating capacity KW	kW	7.8	11.6	18.5	21.8	26.5
Rated power input KW	kW	1.5	2.2	3.50	4.20	4.90
Input current	A	7.2	9.5/4.0	6.80	8.50	9.50
COP	kW/kW	5.2	5.3	5.3	5.2	5.4
Max running current	A	11	17.0	12	14	16
Outlet water temp		20°C to 45°C				
Power supply	V/Ph/Hz	220V~/50Hz	220V or 380V	380V/3Ph/50Hz		
Noise level dB(A)	dB(A)	52	55	62	62	63
Unit dimension	Length(A)	mm	1000	670	810	810
	Width(B)	mm	300	640	780	780
	Height(C)	mm	620	850	1050	1050
Unit Weight	kg	73	115	145	155	170
Working ambient temp rang	°C	-15°C -43°C				
Throttle		EEV				
Refrigerant type		R417A, R407C,R410A optional				
Refrigerant charge qty	kg	1.3	1.7	2.5	2.5	2.7
Compressor		Scroll Copeland Daikin Sanyo optional				
Compressor qty	pcs	1	1	1	1	1
Evaporator		Blue finned aluminum tube heat exchanger				
Hot water side	Heat exchanger type	High efficiency titanium tube heat exchanger				
	Water flow	m³/h	1.70	2.60	4.30	5.10
	Connection in / out	DN	32	40	50	50

Test heating conditions: Ambient temp 24°C / 19°C, inlet water temp 28°C, outlet water temp 32°C.

## Product Features



- » High efficiency,  
The pool heat pump TAS series, COP over 5.3, great save electricity and get a comfortable life.
- » Environmentally friendly  
Uses clean energy and not use oil, coal, gas, and no emission of harmful gas in running course.
- » Easy operation  
Intelligent control panel, easily control the temperature needed, can set timer ON/OFF.
- » Long operation life  
With world famous components, perfect producing technology and strict quality control, its service life

## Technical Parameters

Model		TAS-10	TAS-12	TAS-15	TAS-20	TAS-25
Rated heating capacity KW	kW	38.5	45.5	56.5	76	92
Rated power input KW	kW	7.10	8.40	10.7	14.20	17.20
Input current	A	14.00	15.00	22.0	29.00	32.00
COP	kW/kW	5.4	5.4	5.3	5.4	5.3
Max running current	A	24	26	36	48	52
Outlet water temp		20°C to 45°C				
Power supply	V/Ph/Hz	380V/3Ph/50Hz				
Noise level dB(A)	dB(A)	63	63	64	68	68
Unit dimension	Length(A)	mm	810	1450	1450	1700
	Width(B)	mm	780	780	780	900
	Height(C)	mm	1050	1200	1400	1250
Unit Weight	kg	235	275	320.0	380	550
Operating temp limits: Air	°C	-15°C -43°C				
Throttle		EEV				
Refrigerant type		R417A, R407C,R410A optional				
Refrigerant charge qty	kg	2.5*2	2.7*2	3.5*2	4.0*2	5.5*2
Compressor		Scroll Copeland, Sanyo Daikin optional				
Compressor qty	pcs	2	2	2	2	2
Evaporator		Blue finned aluminum tube heat exchanger				
Hot water side	Heat exchanger type	High efficiency titanium tube heat exchanger				
	Water flow	m³/h	8.50	10.20	12.50	16.50
	Connection in / out	DN	63	63	75	75

Test conditions: Ambient temp 24°C, inlet water temp 28°C, outlet water temp 32°C

### Product Features



- Work at -25°C low temperature;
- High-efficient scroll EVI Copeland compressor;
- R410A/R407C refrigerant;
- Automatic defrosting and anti-freezing function;
- General testing and operational test carried out for every unit before package in the factory.

### Technical Parameters

Model		TAE-03	TAE-05	TAE-06	TAE-07	TAE-10	
Low temp heating capacity(1)	kW	9.7	15.3	19.5	22.1	31	
Input power(1)	kW	2.6	4.1	5.2	5.95	8.35	
Hot water output(1)	T/h	0.21	0.33	0.42	0.48	0.67	
Super low temp heating capacity(2)	kW	5.8	9.3	11.5	13.6	19.2	
Input power(2)	kW	2.45	3.95	4.85	5.75	8.1	
Hot water output(2)	T/h	0.12	0.2	0.25	0.29	0.41	
Max running current	A	7.5/17.1	13/28.5	14.5/34.2	16	24	
Power source	V/Ph/Hz	220V/1Ph or 380V/3Ph			380V/3Ph/50Hz		
Nosie level	dB(A)	≤60	≤60	≤60	≤65	≤67	
Unit size	Length(A)	mm	710/1030	750/1180	750/1340	920/1340	1400
	Width(B)	mm	710/480	750/430	750/490	860/490	720
	Height(C)	mm	840/850	1030/1310	1030/1410	1170/1410	1030
Unit quality	kg	120	155	175	180	280	
Working temp range	°C	-25°C~43°C					
Rated/Max outlet water temp	°C	55°C/60°C					
Throttle		Electronic expansion valve					
Refrigerant		R410A/R407C optional					
Refrigerant charge qty	kg	2.0	2.7	3.3	3.5	2.75*2	
Compressor		Hermetically sealed scroll Copeland					
Compressor qty	pcs	1	1	1	1	2	
Evaporator		Blue finned aluminum tube heat exchanger					
Adding-on		Electric bottom heater installed					
Hot water side	Type	Tank type/ plate heat exchanger					
	Water flow	m³/h	1.90	3.50	4.20	4.80	6.9
	Connection pipe size	DN	20	25	25	25	32
Advised heating area	m²	50~80	80~110	110~130	130~160	160~220	

Test conditions:

- (1)、Low temp heating: Air source side DB/WB is 7°C / 6°C , outlet water temp 45°C .
- (2)、Super low temp heating: Air source side DB/WB is -12°C / -14°C , outlet water temp 41°C .

Lincool - Keep Cool Save More!

### Product Features



### Technical Parameters

Model		TAE-12	TAE-15	TAE-20	TAE-25	TAE-30	TAE-50	
Low temp heating capacity(1)	kW	37.5	45.7	62.8	78.5	92.5	158	
Input power(1)	kW	10.1	12.3	16.9	21.2	24.8	42.5	
Hot water output(1)	T/h	0.81	0.98	1.35	1.69	1.99	3.4	
Super low temp heating capacity(2)	kW	23.5	28.5	38.5	48.9	57.1	98.5	
Input power(2)	kW	9.8	12.05	16.5	20.6	24.2	41.5	
Hot water output(2)	T/h	0.51	0.61	0.83	1.05	1.23	2.12	
Max running current	A	28.8	36	48	66	38	132	
Power source	V/Ph/Hz	380V/3Ph/50Hz						
Nosie level	dB(A)	≤68	≤68	≤70	≤72	≤72	≤75	
Unit size	Length(A)	mm	1500	1500	1850	2000	2300	2300
	Width(B)	mm	700	800	1000	1100	1100	1260
	Height(C)	mm	1350	1500	1950	1930	2070	2250
Unit quality	kg	350	480	720	780	910	1350	
Working temp range	°C	-25°C~43°C						
Rated/Max outlet water temp	°C	55°C/60°C						
Throttle		Electronic expansion valve						
Refrigerant		R410A/R407C optional						
Refrigerant charge qty	kg	3.2*2	3.5*2	4.0*2	5.5*2	6.5*2	3.2*4	
Compressor		Hermetically sealed scroll Copeland						
Compressor qty	pcs	2	2	2	2	2	4	
Evaporator		Blue finned aluminum tube heat exchanger						
Adding-on		Electric bottom heater installed						
Hot water side	Type	Tank type/ plate heat exchanger optional		shell tube heat exchanger optional				
	Water flow	m³/h	8.5	10.5	13.8	16.5	21	33.5
	Connection pipe size	DN	32	40	50	50	65	80
Advised heating area	m²	220~260	260~300	300~450	450~550	500~600	600~1100	

Test conditions:

- (1)、Low temp heating: Air source side DB/WB is 7°C / 6°C , outlet water temp 45°C .
- (2)、Super low temp heating: Air source side DB/WB is -12°C / -14°C , outlet water temp 41°C .

# Household small heat pump (TAN-FT/ZT series)

## Product Features

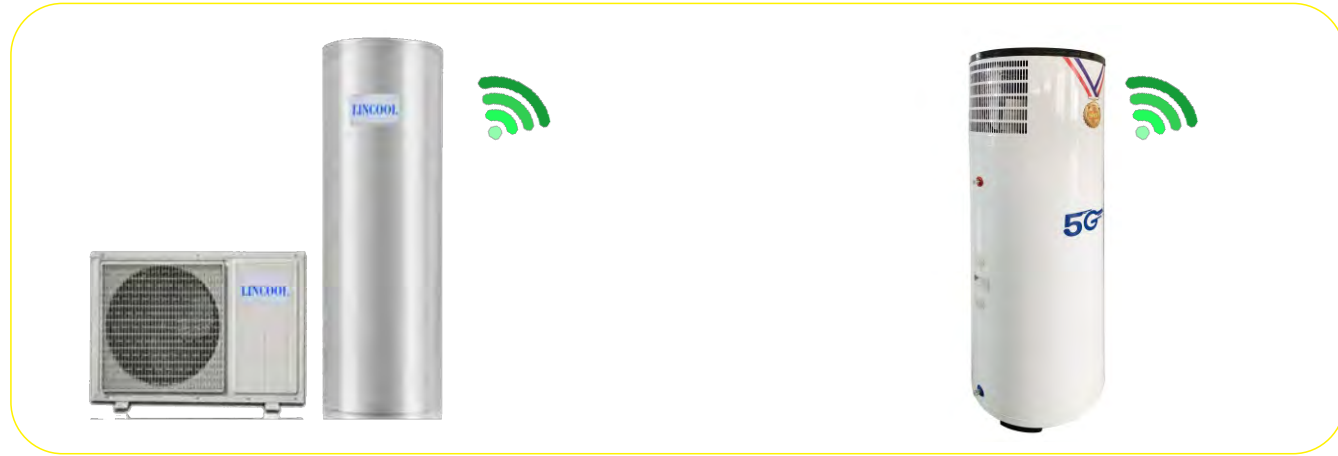

- » Work at -15°C low temperature.
- » Heat pump outdoor unit + indoor unit design or all in one design.
- » High-efficient Rotary compressor Panasonic.
- » R410A refrigerant.
- » It easy to install and use, balcony, walkway, miscellaneous house, courtyard, indoor, rooftop, exterior wall, etc.,
- » General testing and operational test carried out for every unit before package in the factory.

## Technical Parameters

Model		TAN -01FT	TAN -015FT	TAN -02FT	TAN -01ZT	TAN -015ZT	TAN -02ZT	
Rated heating capacity	kW	3.6	4.8	7.1	3.6	4.8	7.1	
Rated power input	kW	0.89	1.18	1.72	0.89	1.18	1.72	
Input current	A	3.7	4.71	7.11	3.7	4.71	7.11	
Max running current	A	6.00	7.50	11.00	6.00	7.50	11.00	
COP	KW/KW	4.05	4.1	4.13	4.05	4.1	4.13	
Power supply	V/Ph/Hz	220V~50Hz						
Noise level	dB(A)	45	48	50	45	48	50	
Unit dimension	Length(A)	600	780	840	550	600	600	
	Width(B)	235	258	285	550	600	600	
	Height(C)	500	540	610	1350	1450	1750	
Unit Weight	kg	35	40	45	70	80	90	
Operating temp limits: Air	°C	-15°C~43°C						
Refrigerant type		R410A						
Compressor		Rotary Panasonic						
Water tank	Type	Presistant type water tank						
	Connection in	DN	15	15	15	15	15	
	Connection out	DN	20	20	20	20	20	
	Refrigerant liquid pipe	mm	6.35	6.35	6.35	built-in	built-in	built-in
	Refrigerant gas pipe	mm	9.52	9.52	12.7	built-in	built-in	built-in
Suitable water tank capacity	L	100/150	150/200	200/320/500	150/200	150/200	200/320	

Test conditions: air source side DB/WB is 20°C / 15°C, inlet water temp 15°C, outlet water temp 55°C.

# Split Air to Water Heat Pump (TAN-S series)

# LINCOOL

## Product Features



## Technical Parameters

Split air water heat pump		DC inverter split heat pump			On/Off Split heat pump			
Model		TAN-03BPS	TAN-05BPS	TAN-06BPS	TAN-03S	TAN-05S	TAN-06S	TAN-10S
Heating capacity	KW	8.5	15.2	18.2	8.4	15	17.8	32.6
Input power	KW	2.45	4.35	5.1	2.55	4.45	5.2	9.38
Heating running current	A	13.7	26.8	34	13.8/4.8	8.4	9.2	16.8
Max running current	A	17	34	42	17/8	12	16	24
Power source	V/Ph/Hz	220V/1N/50HZ			380V or 220V	380V/3N/50HZ		
Noise level	dB(A)	<55	<58	<59	<55	<58	<60	<64
Outdoor unit	Up fan W × D × H	mm	/	/	670*640*820	810*780*1050	1390*670*820	1450*780*1050
	Side fan W × D × H	mm	1120*480*810	1030*480*1340	1030*480*1340	830*310*710	830*310*1260	1300*420*1245
	Unit weight	kg	115	145	165	120	155	170
Indoor unit	W × D × H	mm	370*220*450	500*260*700	500*260*700	370*200*450	500*260*700	500*260*700
	Unit weight	kg	10	12	14	10	12	14
Working temp range	°C	-15°C~43°C						
Throttle type		Electric expansion valve						
Refrigerant	Type	R410A/R407C/R417A/R134a						
	Charge qty	kg	2.5	3.7	4.2	2.6	3.7	4.3
	Max working pressure	Bar	38	38	38	38	38	38
Compressor	Type	Inverter Rotary Compressor(MITSUBISHI)			Hermetically sealed scroll compressor(COPELAND)			
	Heat exchanger type	Finned tube heat exchanger						
Air source side	Qty	pcs	1	1	1	1	1	2
	Motor power	KW	0.1	0.12*2	0.12*2	0.1	0.12*2	0.12*2
Hot water side	Heat exchanger type	Tube in tube heat exchanger						
	Water flow	m³/H	2.3	3.2	3.6	2.3	3.2	3.6
	Pipe size	DN	20	25	25	20	25	25
	Max working pressure	kPa	1000	1000	1000	1000	1000	1000

Test conditions:

- 1、Cooling: Air source side DB/WB is 35°C / --, inlet water temp 12°C, outlet water temp 7°C.
- 2、Heating(1): Air source side DB/WB is 7°C / 6°C, inlet water temp 40°C outlet water temp 45°C.
- 3、Heating(2): Air source side DB/WB is -12°C / -14°C, inlet water temp 40°C, outlet water temp 45°C.

### Product Features



- Cooling in summer and heating in winter. Scroll Copeland or Sanyo or Daikin compressor.
- Electronic expansion valve inside. Very good sound control.
- R410A, R417A or R407C refrigerant optional.
- Connect to fan coil or convector design.
- Intelligent controller adjustment by quick-mind microprocessor.
- General testing and operational test carried out for every unit before package in the factory.

### Technical Parameters

Model		TAN-02R	TAN-03R	TAN-05R	TAN-06R	TAN-07R	TAN-10R	
Heating capacity	kW	6.3	9.2	16.3	19	22.5	32.6	
Input power	kW	1.85	2.7	4.65	5.4	6.2	9.3	
Cooling capacity	kW	5.2	7.6	13.5	16.2	18.5	27.2	
Input power	kW	1.7	2.45	4.35	5.2	6	8.75	
Input current	A	7.11	11.23/4.1	6.7	8	11	13.34	
Max running current	A	11	17.1/7.5	12	14	16	24	
Power source	V/Ph/Hz	220V~/50Hz	220V or 380V	380V/3Ph/50Hz				
Nosie level	dB(A)	53	55	62	62	63	63	
Unit size	Length(A)	mm	1000	*770/710	*1180/750	*1180/750	*1340/920	*1500/1450
	Width(B)	mm	300	*420/710	*430/750	*430/750	*490/860	*440/780
	Height(C)	mm	620	*1250/840	*1310/1030	*1310/1030	*1410/1170	*1705/1050
Unit quality	kg	75	115	145	155	175	245	
Working temp range	°C	-15°C ~ -43°C						
Throttle		EEV						
Refrigerant		R410A/R417A/R407C optional						
Refrigerant charge qty	kg	1.25	1.7	2	2.3	2.5	2.0*2	
Compressor		Rotary Panasonic	Scroll Sanyo, Copeland, Daikin optional					
Compressor qty	pcs	1	1	1	1	1	2	
Evaporator		Blue finned aluminum tube heat exchanger						
Air conditioning side	Heat exchanger type	Copper tube in tube heat exchanger						
	Water flow	m³/h	1.08	1.90	2.80	3.90	4.60	6.2
	Connection in / out	DN	20	20	25	25	32	32

Test conditions:

- 1、Cooling: ambient temp 35°C, AC side inlet water temp 12°C, outlet water temp is 7°C ;
- 2、Heating: Air source side DB/WB 7°C /6°C, AC side inlet water temp 40°C, outlet water temp 45°C .

### Product Features

28.82 mm



- » Easy operation  
Intelligent control panel, easily control the temperature needed, can set timer ON/OFF.
- » Modular design  
With modular design, compressor can automatically start and stop with sequence, more stable and work long life time.
- » High efficiency  
Heat pump its consumption only 1/4 of electric heater, 1/3 of gas heater, 1/2 of solar energy.
- » Widely application  
Different capacity can meet wide demands of ordinary families, factories, schools, hotels, restaurants, hospitals, supermarkets...

### Technical Parameters

Model		TAN-12R	TAN-15R	TAN-20R	TAN-25R	TAN-30R	TAN-50R	
Heating capacity	kW	39.8	48.5	65.5	78.5	97.5	157	
Input power	kW	11.2	13.8	18.5	23.5	27.5	47	
Cooling capacity	kW	32.5	41.2	54.5	66.8	81	133.5	
Input power	kW	10.5	13.5	17.5	22.1	26.2	44.2	
Input current	A	16	20	26.51	33.1	40	66	
Max running current	A	28	36	48	56	72	112	
Power source	V/Ph/Hz	380V/3Ph/50Hz						
Nosie level	dB(A)	64	66	68	68	68	72	
Unit size	Length(A)	mm	1500	1500	1850	2000	2300	
	Width(B)	mm	700	800	1000	1100	1260	
	Height(C)	mm	1350	1500	1950	1930	2070	2250
Unit quality	kg	280	310	560	630	850	1350	
Working temp range	°C	-15°C ~ -43°C						
Throttle		EEV						
Refrigerant		R410A/R417A/R407C optional						
Refrigerant charge qty	kg	2.3*2	2.8*2	4.0*2	6.0*2	6.5*2	6.0*4	
Compressor		Scroll compres sor Copeland, Sanyo, Daikin optional						
Compressor qty	pcs	2	2	2	2	2	4	
Evaporator		Blue finned alumin um tube heat exchanger						
Air conditioning side	Heat exchanger type	Copper tube in tube heat exchanger	Shell tube heat exchanger					
	Water flow	m³/h	7.80	9.80	12.50	15.50	17.50	32.00
	Connection in / out	DN	32	40	50	50	65	80

Test conditions:

- 1、Cooling: ambient temp 35°C, AC side inlet water temp 12°C, outlet water temp is 7°C ;
- 2、Heating condition: Air source side DB/WB 7°C /6°C, AC side inlet water temp 40°C, outlet water temp 45°C

## Product Features



## Technical Parameters

Model		TAE-03R	TAE-05R	TAE-06R	TAE-07R	TAE-10R	TAE-12R	
Cooling capacity(1)	kW	7.9	13.5	15.5	18.2	25.8	32	
Input power(1)	kW	2.5	4.1	4.9	5.8	8.15	9.8	
Heating capacity(2)	kW	9.5	15.1	19.1	21.7	30.4	36.8	
Input power(2)	kW	2.6	4.1	5.2	5.95	8.35	10.1	
Heating capacity(3)	kW	5.8	9.3	11.5	13.6	19.2	23.5	
Input power(3)	kW	2.45	3.95	4.85	5.75	8.1	9.8	
Max running current	A	7.5/17.1	13/28.5	14.5/34.2	16	24	28.8	
Power source	V/Ph/Hz	220V/1Ph or 380V/3Ph			380V/3Ph/50Hz			
Nosie level	dB(A)	≤60	≤60	≤60	≤65	≤67	≤68	
Unit size	Length(A)	mm	710/770	750/1180	750/1340	920/1340	1400	1500
	Width(B)	mm	710/420	750/430	750/490	860/490	720	700
	Height(C)	mm	840/1250	1030/1310	1030/1410	1170/1410	1030	1350
Unit quality	kg	120	155	175	180	280	350	
Working temp range	℃	-25℃~43℃						
Rated/Max outlet water temp	℃	55℃/60℃						
Throttle		Electronic expansion valve						
Refrigerant		R410A/R407C optional						
Refrigerant charge qty	kg	2.6	3.4	4	5.2	3.5*2	4.0*2	
Compressor		Hermetically sealed scroll compressor ( Copeland )						
Compressor qty	pcs	1	1	1	1	2	2	
Evaporator		Blue finned aluminum tube heat exchanger						
Adding-on		Electric bottom heater installed						
Hot water side	Type	Copper tube in tube heat exchanger/ plate heat exchanger						
	Water flow	m³/h	1.90	3.50	4.20	4.80	6.90	8.50
	Connction in / out	DN	20	25	25	25	32	32
Advised cooling/heating area	m³	50~80	80~110	110~130	130~160	160~220	220~260	

Test conditions:

- (1)、Rated cooling condition: Air source side DB/WB is 35℃ /~, outlet water temp 7℃.
- (2)、Low temp heating: Air source side DB/WB is 7℃ /6℃, outlet water temp 45℃.
- (3)、Super low temp heating: Air source side DB/WB is -12℃ /-14℃, outlet water temp 41℃

## Product Features



## Technical Parameters

Model		TAE-15R	TAE-20R	TAE-25R	TAE-30R	TAE-50R	
Cooling capacity(1)	kW	39.5	52.5	66.5	79.5	132	
Input power(1)	kW	12.1	16.5	21.2	24.5	42.2	
Heating capacity(2)	kW	44.8	61.5	76.9	90.7	155	
Input power(2)	kW	12.3	16.9	21.20	24.80	42.5	
Heating capacity(3)	kW	28.5	38.5	48.9	57.1	98.5	
Input power(3)	kW	12.05	16.5	20.6	24.2	41.5	
Max running current	A	36	48	66	38	132	
Power source	V/Ph/Hz	380V/3Ph/50Hz					
Nosie level	dB(A)	≤68	≤70	≤72	≤72	≤75	
Unit size	Length(A)	mm	1500	1850	2000	2300	2300
	Width(B)	mm	800	1000	1100	1100	1260
	Height(C)	mm	1500	1950	1930	2070	2250
Unit quality	kg	480	720	780	910	1350	
Working temp range	℃	-25℃~43℃					
Rated/Max outlet water temp	℃	55℃/60℃					
Throttle		Electronic expansion valve					
Refrigerant		R410A/R407C optional					
Refrigerant charge qty	kg	5.0*2	7.0*2	8.5*2	9.0*2	8.5*4	
Compressor		Hermetically sealed scroll Copeland compressor					
Compressor qty	pcs	2	2	2	2	4	
Evaporator		Blue finned aluminum tube heat exchanger					
Adding-on		Electric bottom heater installed					
Hot water side	Type	shell tube heat exchanger					
	Water flow	m³/h	10.50	13.80	16.50	21.00	33.5
	Connction in / out	DN	40	50	50	65	80
Advised cooling/heating area	m³	260~300	300~450	450~550	500~600	600~1100	

Test conditions:

- (1)、Rated cooling condition: Air source side DB/WB is 35℃ /~, outlet water temp 7℃.
- (2)、Low temp heating: Air source side DB/WB is 7℃ /6℃, outlet water temp 45℃.
- (3)、Super low temp heating: Air source side DB/WB is -12℃ /-14℃, outlet water temp 41℃.

### Product Features



- ◆ Applicable for different source of ground source installation conditions, as deep ground water system, shallow ground water system, or water pipe laying in soil system.
- ◆ Work very stable at low ambient temperature
- ◆ High efficient scroll compressor
- ◆ R410A/R417A/R407C optional

### Technical Parameters

Model		TWN-03	TWN-05	TWN-06	TWN-07	TWN-10	TWN-12	
Rated heating capacity	kW	11.2	17.5	21.6	25.7	35.4	43.5	
Rated power input	kW	2.45	3.8	4.65	5.5	7.6	9.3	
Hot water output	T/H	0.24	0.38	0.46	0.55	0.76	0.94	
Input current	A	4.2	7.6	9.2	11.5	15.2	18.5	
Max running current	A	7.5	12	13	17	24	26	
COP	kW/kW	4.57	4.6	4.64	4.67	4.65	4.67	
Rated/Max outlet water temp		55°C / 60°C						
Power supply	V/Ph/Hz	380V/3N/50Hz						
Noise level	dB(A)	53	56	58	58	60	63	
Unit dimension	Length(A)	mm	620	680	680	800	800	
	Width(B)	mm	725	800	800	1080	1080	
	Height(C)	mm	595	720	720	720	900	1050
Unit Weight	kg	110	140	155	165	220	250	
Throttle		EEV						
Refrigerant type		R410A/R417A/R407C optional						
Refrigerant charge qty	kg	1.7	2	2.3	2.5	2.0*2	2.3*2	
Compressor		Scroll Copeland Sanyo Daikin optional						
Compressor qty	pcs	1	1	1	1	2	2	
Water source side	Heat exchanger type	Spiral copper tube in tube heat exchanger						
	Water flow	m³/h	1.80	2.80	3.50	4.20	5.50	6.80
	Connction in / out	DN	20	25	25	25	32	32
Hot water side	Heat exchanger type	Spiral copper tube in tube heat exchanger						
	Water flow	m³/h	1.93	3.01	3.71	4.50	6.09	7.48
	Connection in / out	DN	20	25	25	25	32	32

Test conditions: water source side inlet water temp 15°C , outlet water temp 55°C .

### Product Features



With adding one stainless steel heat exchanger, it water source side could be dirty water, this system fit for sandy water source or big shower places which collect the waste hot water heating energy these special conditions.

### Technical Parameters

Model		TWN-20	TWN-25	TWN-36	TWN-60	TWN-75	TWN-90	
Rated heating capacity	kW	77.8	88.7	133.2	231	280.9	346	
Rated power input	kW	15.07	17.05	25.57	45.09	56.06	67.64	
Hot water output	T/H	1.67	1.91	2.86	4.96	6.04	7.44	
Input current	A	26.68	30.1	44.85	76.98	97.38	117.5	
Max running current	A	33.6	44.6	66.9	120.6	170.6	180.9	
COP	kW/kW	5.2	5.2	5.2	5.1	5	5.1	
Rated/Max outlet water temp		55°C / 60°C						
Power supply	V/Ph/Hz	380V/3Ph/50Hz						
Noise level	dB(A)	65	66	70	74	79	82	
Unit dimension	Length(A)	mm	2100	2100	2330	2500	2700	2700
	Width(B)	mm	500	500	750	850	850	850
	Height(C)	mm	1350	1350	1300	1500	1380	1550
Unit Weight	kg	410	550	830	1160	1380	1650	
Throttle		EEV						
Refrigerant type		R410A/R417A/R407C optional						
Refrigerant charge qty	kg	4.8*2	6.5*2	6.5*3	6.5*5	7.5*3	8.5*3	
Compressor		Hermetically sealed scroll compressor						
Compressor qty	pcs	2	2	3	5	3	3	
Water source side	Heat exchanger type	Shell tube heat exchanger						
	Water flow	m³/h	13.38	15.26	22.9	39.72	48.3	59.5
	Connection in / out	DN	50	50	80	80	100	125
Hot water side	Heat exchanger type	Shell tube heat exchanger						
	Water flow	m³/h	10.79	12.33	18.5	31.96	38.66	47.87
	Connection in / out	DN	50	50	80	80	100	125

Test condition: water source side inlet water temp 15°C , outlet water temp 55°C .

### Product Features



- Max outlet water temp up to 60°C;
- High efficiency and energy saving, COP up to 4.7;
- Intelligent microprocessor controller;
- 100% water circuit;
- Running stable and fault self-checking;
- World famous branded components built inside;
- Perfect protection design as high/low pressure protection, water flow protection, overheating protection, phase order protections and so on.

### Technical Parameter

Model		TWN-03R	TWN-04R	TWN-05R	TWN-06R	TWN-07R	TWN-10R	TWN-12R	
Rated heating capacity	kW	11.2	14	17.5	21.6	25.7	35.4	43.5	
Rated power input	kW	2.45	3.25	3.8	4.65	5.5	7.6	9.3	
Input current		4.2	5.6	7.6	9.2	11.5	15.2	18.5	
Rated cooling capacity	kW	8.6	11	13.5	16.8	19.8	27.5	32.9	
Cooling power input	kW	2.30	3.06	3.60	4.35	5.2	7.20	8.50	
Input current	A	4.0	5.34	7.2	8.7	10.8	14.4	17	
Max running current	A	7.5	10	12	13	17	24	26	
Power supply	V/Ph/Hz	380V/3Ph/50Hz							
Noise level	dB(A)	53	54	56	58	58	60	63	
Unit dimension	Length(A)	mm	620	680	680	680	800	800	
	Width(B)	mm	725	800	800	800	1080	1080	
	Height(C)	mm	595	720	720	720	900	1050	
Unit Weight	kg	110	130	140	155	165	220	250	
Throttle		Electronic expansion valve							
Refrigerant type		R410A/R417A/R407C optional							
Refrigerant charge qty	kg	1.7	2	2	2.3	2.5	2.0*2	2.3*2	
Compressor		Scroll Copeland/Daikin/Sanyo optional							
Compressor qty	pcs	1	1	1	1	1	2	2	
Water source side	Heat exchanger type	Spiral tube in tube heat exchanger							
	Water flow	m³/h	2.2	2.8	3.2	4.2	4.8	6.5	8.5
	Connection in / out	DN	20	25	25	25	25	32	32
A/C side	Heat exchanger type	Spiral tube in tube heat exchanger							
	Water flow	m³/h	1.89	2.15	3.01	3.71	4.5	6.09	7.48
	Connection in / out	DN	20	25	25	25	25	32	32

Test conditions: 1. Rated cooling condition: water source side inlet water temp 18°C, outlet water temp 29°C, water chiller side inlet water temp. 12°C, outlet water temp. 7°C.  
 2. Rated heating condition: water source side inlet water temp is 15°C, AC side inlet water temp 40°C, outlet water temp 45°C.

### Product Features



Geothermal heat pump or ground source heat pump(GSHP) is a central heating system that pumps heat from the ground, it uses the earth as a heat source. This design takes advantage of the moderate temperature in the ground to boost efficiency and reduce the operational costs of heating systems. It is applicable for different sources of geothermal energy installation conditions, as deep underground water system of drill well, shallow groundwater system and water pipe laying in soil system.

### Technical Parameter

Model		TWN-20R	TWN-25R	TWN-36R	TWN-60R	TWN-75R	TWN-90R	
Rated heating capacity	kW	80.6	92.2	138.3	234.8	280.9	352.2	
Rated power input	kW	15.2	19	28.5	50.2	60.5	75.3	
Input current	A	29.2	33.2	49.8	86.8	107.6	130.2	
Rated cooling capacity	kW	58	74.2	111.4	192	230	288	
Cooling power input	kW	13.7	17.1	25.7	45.2	54.5	67.8	
Input current	A	23.4	26.2	39.2	72.1	93.8	108.2	
Max running current	A	33.6	44.6	66.9	120.6	170.6	180.9	
Power supply	V/Ph/Hz	380V/3Ph/50Hz						
Noise level	dB(A)	65	66	70	74	79	82	
Unit dimension	Length(A)	mm	2100	2100	2330	2500	2700	
	Width(B)	mm	500	500	750	850	850	
	Height(C)	mm	1350	1350	1300	1500	1380	
Unit Weight	kg	410	550	830	1160	1380	1650	
Throttle		Electronic expansion valve						
Refrigerant type		R410A/R417A/R407C optional						
Refrigerant charge qty	kg	4.8*2	6.5*2	6.5*3	7.5*2	7.5*3	8.5*3	
Compressor		Hermetically sealed scroll compressor						
Compressor qty	pcs	2	2	3	2	3	3	
Water source side	Heat exchanger type	Shell tube heat exchanger						
	Water flow	m³/h	13.38	15.26	22.9	39.72	48.3	59.5
	Connection in / out	DN	50	50	80	80	100	125
A/C side	Heat exchanger type	Shell tube heat exchanger						
	Water flow	m³/h	10.79	12.33	18.5	31.96	38.66	47.87
	Connection in / out	DN	50	50	80	80	100	125

Test conditions:

1. Rated cooling condition: water source side inlet water temp 18°C, outlet water temp 29°C, water chiller side inlet water temp. 12°C, outlet water temp. 7°C.  
 2. Rated heating condition: water source side inlet water temp is 15°C, AC side inlet water temp 40°C, outlet water temp 45°C.

# Air Source Heat Pump

## Cooling & Heating & Hot Water Unit (TAM series)

# Geothermal Heat Pump

## Cooling & Heating & Hot Water Unit (TWM series)

# LINCOOL

### Technical Parameters

Model		TAM-03	TAM-04	TAM-05	TAM-06	TAM-07	TAM-10
AC heating with Hot water	Heating capacity kW	11	14.8	19.00	22	30.40	38
	Hot water output T/H	0.24	0.32	0.41	0.48	0.66	0.82
	Input power KW	2.44	3.2	4.07	4.88	6.52	8.15
	input current A	11.23	16	7.76	22.46	29	15.53
	COP	4.51	4.62	4.67	4.51	4.66	4.66
AC cooling with heat recovery for hot water	Cooling capacity kW	7.8	10	13	15.6	20.8	25.9
	AC Water flow M <sup>3</sup> /H	1.34	1.72	2.24	2.68	3.59	4.45
	Heating capacity kW	10.5	14.5	16.5	21	26.4	33
	Hot water output T/H	0.22	0.27	0.35	0.42	0.58	0.7
	Input power KW	2.3	3.1	3.7	4.6	5.92	7.4
AC cooling	Rated input current A	10.59	16.2	7.1	21.17	26	14.2
	EER+COP	7.96	7.88	7.97	7.96	7.96	7.96
	Cooling capacity kW	7.44	9.8	12.4	14.88	19.84	24.8
	AC Water flow M <sup>3</sup> /H	1.28	1.68	2.13	2.56	3.4	4.27
	Input power KW	2.58	3.4	4.3	5.16	6.88	8.6
AC cooling	Rated input current A	11.87	16.5	7.6	22.09	12.16	15.2
	EER	2.88	2.88	2.88	2.88	2.88	2.88
Rated & Max water temp °C		55°C and 60°C					
Power source V/PH/Hz		220V/1Ph/50Hz			380V/3Ph/50Hz		
Noise level dB(A)		<50	<54	<55	<55	<55	<55
Unit size W x D x H mm		710*710*810	810*780*1050	810*780*1050	1300*640*740	1300*640*740	1450*780*1050
Wood Packing W x D x H mm		810*810*980	910*880*1220	910*880*1220	1400*740*910	1400*740*910	1550*880*1220
Net weight Kg		110	165	175	220	340	340
Throttle Type		Electronic expansion valve/Thermal expansion valve					
Refrigerant Qty kg		3.2	4.8	5.2	3.2*2	5.2*2	5.2*2
Sanyo/Copeland Comp. Pcs		1	1	1	1	1	2
Protection		Built-in protection as overheating protection, sequence protection, undervoltage protection, time delay start protection etc					
Condens e	Heat exchanger type	Finned tube heat exchanger					
	Qty pcs	1	1	1	1	1	1
	Fan type	Axial big twist angle fan					
	Motor KW	0.2	0.3	0.3	0.37	0.45	0.6
Hot water	Heat exc hanger type	Efficient tube in tube heat exchanger with Max working pressure 1000 kPa					
	Qty pcs	1	1	1	1	1	1
	Water flow M <sup>3</sup> /H	1.89	2.45	3.27	3.78	4.3	6.54
	Pressure Loss KPa	27	30	32	30	34	36
Air Conditioner	Pipe size mm	20	25	25	25	32	32
	Heat exchanger type	Efficient tube in tube heat exchanger					
	Quantity	1	1	1	1	1	1
	water flow M <sup>3</sup> /H	1.34	1.68	2.24	2.68	3.44	4.45
	Pressure Loss kPa	12	13	13	12	15	15
Air Conditioner	Pipe size mm	20	25	25	25	32	32
	Water side max working temp kPa	1000	1000	1000	1000	1000	1000

- 1、Rated cooling working condition: Air source side inlet water temp is 35°C, AC side inlet water temp is 12°C, outlet water temp is 7°C
- 2、Rated heating&hot water condition: Air source side DB/WB is 20°C/15°C, initial hot water temp 15°C, ending hot water temp 55°C; AC side inlet water temp 40°C, outlet water temp 45°C.
- 3、Rated cooling&hot water working condition: initial hot water temp 15°C, ending hot water temp 55°C; AC side inlet water temp 12°C outlet water temp 7°C.

### Technical Parameters

Model		TWM-03	TWM-05	TWM-06	TWM-10	TWM-12
Hot water	Heating capacity kW	10.5	17.4	21.6	34.7	43.1
	Hot water output T/H	0.23	0.37	0.46	0.75	0.93
	Input power KW	2.25	3.7	4.58	7.43	9.24
	Rated input current A	11.25	7.4	9.16	14.86	18.48
	COP	4.67	4.7	4.72	4.67	4.66
AC heating	Heating capacity kW	9.5	15.9	18.8	23.9	33.6
	Input power KW	2.6	4.2	5	6.3	9.1
	Rated input current A	12.8	8.6	10.2	12.8	18
AC cooling	COP	3.65	3.78	3.76	3.79	3.69
	Cooling capacity kW	8.5	14.1	17.5	27.1	32.9
	Input power KW	1.9	2.95	3.7	5.8	7.1
	Rated input current A	9.5	5.9	7.4	11.6	14.2
AC cooling with heat recovery for hot water	EER	4.5	4.8	4.7	4.7	4.6
	Cooling capacity kW	7.4	12.1	15.2	23.5	28.6
	Heating capacity kW	9.2	14.5	18.5	30	36.7
	Hot water output T/H	0.2	0.3	0.4	0.65	0.8
	Input power KW	2.25	3.7	4.75	7.2	9.2
	Rated input current A	9.4	6	7.6	12.2	14.8
AC cooling with heat recovery for hot water	EER+COP	7.4	7.2	7.1	7.4	7.1
	Rated & Max water temp °C	55 °C and 60 °C				
Power source V/PH/Hz		380V or 220V	380V/3N/50Hz			
Noise level dB(A)		<50	<55	<55	<58	<60
Unit size W x D x H mm		620*825*595	680*1020*770	680*1020*770	800*1080*1300	800*1080*1300
Wood Packing W x D x H mm		720*925*700	780*1120*890	780*1120*890	900*1180*1420	900*1180*1420
Net weight Kg		135	170	190	260	300
Throttle Type		Thermal expansion valve				
Refrigerant Qty kg		1.7	2	2.5	4	5
Sanyo Compressor Pcs		1	1	1	2	2
Protection		Built-in protection overheating protection, phase sequence protection, undervoltage protection, time delay start protection etc .				
Condens e	Type	Efficient tube in tube heat exchanger				
	Quantity pcs	1	1	1	1	1
	Water flow	0.81	1.23	1.66	2.57	3.13
	Pressure Loss Kpa	10	12	12	14	18
	Pipe size	20	25	25	32	32
Hot water	Type	Efficient tube in tube heat exchanger				
	Quantity	1	1	1	1	1
	Water flow M <sup>3</sup> /H	1.81	2.99	3.72	5.97	7.41
	Pressure Loss Kpa	10	12	12	14	18
	Pipe size mm	20	25	25	32	32
Air Conditioner	Type	Efficient tube in tube heat exchanger				
	Quantity	1	1	1	1	1
	water flow M <sup>3</sup> /H	1.46	2.43	3.01	4.66	5.66
	Pressure Loss Kpa	10	12	12	14	18
	Pipe size mm	20	25	25	32	32
Air Conditioner	Water side max working temp kPa	1000	1000	1000	1000	1000

- 1、Hot water condition: water source inlet water temp 20°C, initial water temp 15°C, ending hot water temp 55°C;
- 2、AC cooling condition: Water source inlet water temp 18°C, outlet temp 29°C; AC chiller side inlet 12°C, outlet 7°C;
- 3、AC heating condition: Water source side inlet water temp 15°C, AC side inlet water temp 45°C;
- 4、AC cooling with hot water condition: Hot water inlet temp 15°C, outlet temp 55°C; AC chiller inlet temp 12°C, outlet 7°C.

## Product Features



### Operating Limits

- Thermal carrier fluid: water
- Water temperature: min + 7°C, max +95°C
- Air temperature: min -10°C, max + 40°C
- Supply voltage: rated voltage +/- 10%
- Max water pressure during operation: 10 bars



Air conditioning fan unit is an extremely silent and well – designed fan heater for water connection. It consists of a heat exchanger, an axial fan with motor and a room thermostat for its proper operation. It is used for permanent heating of industrial premises, workshop and storage rooms, as well as places where low noise levels are required like shops, supermarkets and meeting halls. The fan heater can be mounted either on the wall or the ceiling and the water connections can be made on the left or right hand side. The air flow can be regulated in several stages.

The TAF series all designed to be wall mounted (horizontal air flow) and to operate with hot water and chilled water. If used for heating only, TAF series can also be ceiling mounted (vertical air flow).

## Technical Parameter

Model	TAF-10	TAF-20	TAF-30
Air flow m <sup>3</sup> /H	3500~4500	7000~9000	10500~13500
Cooling capacity KW	11KW	21.5KW	31KW
Input power KW	2.2KW	4.4KW	6.6KW
Thermal carrier fluid	Water	Water	Water
Power source	380V/3Ph/50HZ or 220V/1Ph/50HZ		
Adjustable function	Two speeds or single speeds		
Size WxDxH mm	760x400x645	1350x400x645	1840x652x400
Net weight KG	42	80	110
Gross weight KG	50	95	135
Connection pipe size	DN25	DN32	DN40
Out casing	Stainless steel casing or galvanized steel casing painting white		

## Technical Parameter

Model	Inner size	Insulation material thickness	Inner material	Unit size	Packing size	Outcasing material
	(mm)	(mm)	(mm)	(mm)	(mm)	
80L	φ370*1.0	50	SUS304	φ470*850	550*550*930	Powder coating white /SUS 304
100L	φ370*1.0	50	SUS304	φ470*1020	550*550*1100	
150L	φ370*1.0	50	SUS304	φ470*1480	550*550*1560	
200L	φ470*1.5	50	SUS304	φ560*1260	635*635*1360	
260L	φ470*1.5	50	SUS304	φ560*1550	635*635*1650	
320L	φ470*1.5	50	SUS304	φ560*1820	635*635*1920	
400L	φ600*2.0	50	SUS304	φ700*1530	790*790*1630	
500L	φ600*2.0	50	SUS304	φ700*1850	790*790*1950	
600L	φ600*2.0	50	SUS304	φ700*2060	790*790*2160	



## Heat pump more options

### Heat tape by the bottom of machine

Electric heating tape can be installed by the bottom of machine, if there has water didn't leak completely by water pore, then avoid winter freeze of the bottom.

### Rs485 modbus communication protocol

Rs485 is used for building controlling and managing system, from the system, user can read the working station of the unit, some related technical data and alarm information,

### Wifi controller

Wifi controller, the heat pump unit can be controlled by cell phone start or stop, effect remote control of the unit,

### Adding ABB soft starter

Soft starter is used for reduce the starting current, which can prevent excessive current attack power system when starting compressor.

